

Passivity Analysis and Passification for Uncertain Signal Processing Systems

Lihua Xie, *Senior Member, IEEE*, Minyue Fu, and Huaizhong Li

Abstract—The problem of passivity analysis finds important applications in many signal processing systems such as digital quantizers, decision feedback equalizers, and digital and analog filters. Equally important is the problem of passification, where a compensator needs to be designed for a given system to become passive. This paper considers these two problems for a large class of systems that involve uncertain parameters, time delays, quantization errors, and unmodeled high-order dynamics. By characterizing these and many other types of uncertainty using a general tool called integral quadratic constraints (IQC's), we present solutions to the problems of robust passivity analysis and robust passification. More specifically, for the analysis problem, we determine if a given uncertain system is passive for all admissible uncertainty satisfying the IQC's. Similarly, for the problem of robust passification, we are concerned with finding a loop transformation such that a particular part of the uncertain signal processing system becomes passive for all admissible uncertainty. The solutions are given in terms of the feasibility of one or more linear matrix inequalities (LMI's), which can be solved efficiently.

I. INTRODUCTION

THE NOTION of passivity plays an important role in design and analysis of signal processing systems. On one hand, many systems need to be passive in order to attenuate noises effectively. On the other hand, the robustness measure (such as robust stability or robust performance) of a system often reduces to a subsystem or a modified system being passive. For example, it is well known that the suppression of limit cycles of a digital quantizer requires a certain dynamic part of the system to be passive [7]. Another example where passivity analysis finds important use is the so-called decision feedback equalization (DFE) problem. It is shown [6] that a decision feedback equalizer guarantees finite error recovery if certain passivity conditions are satisfied.

Many signal processing systems are feedback systems consisting of both a linear time-invariant (LTI) dynamic part and a nonlinear and/or time-varying part. For example, a differential pulse-code modulation (DPCM) system involves a linear predictor and a quantizer. Time-varying filters are

Manuscript received April 30, 1996; revised December 23, 1997. This work was supported by the Nanyang Technological University Applied Research Fund and by the Australian Research Council. The associate editor coordinating the review of this paper and approving it for publication was Dr. A. Lee Swindlehurst.

L. Xie is with the School of Electrical and Electronic Engineering, Nanyang Technological University, Singapore (e-mail: elhxie@ntu.edu.sg).

M. Fu is with the Department of Electrical and Computer Engineering, University of Newcastle, Callaghan, Australia (e-mail: eemf@ee.newcastle.edu.au).

H. Li is with the School of Engineering, Murdoch University, Perth, Australia (e-mail: li@eng.murdoch.edu.au).

Publisher Item Identifier S 1053-587X(98)05946-7.

popularly used in multirate signal processing [14]. Nonlinear and time-varying systems also arise in many adaptive filtering problems. Passivity analysis is a major tool for studying stability of such systems, especially for high-order systems. In fact, the passivity analysis approach has been used in control problems for a long time to deal with robust stability problems for systems involving nonlinear/time-varying components. See [3], [9], [10], [15]–[17], [20], and [21] for references.

Apart from its direct applications, the notion of passivity is closely related to bounded realness, which is an equally important notion in signal processing. In fact, it is well known that there is a one-to-one relationship between bounded realness and passivity [1]. Consequently, bounded realness analysis can be converted into passivity analysis and vice versa. Bounded real functions find important applications in both single-rate and multirate signal processing [7], [14].

The motivation of our paper stems from the fact that in many applications, the system (or subsystem) that is required to be passive is not a simple LTI transfer function; rather, it involves additional uncertainty. For example, in adaptive DPCM (ADPCM) or adaptive DFE, the filter coefficients are subject to time variations. Even in nonadaptive cases, filter coefficients are also subject to quantization effects. Other uncertainties include unknown time delays in a communication channel, variations in analog components, and unmodeled high order dynamics. Note that if there exists no uncertainty, checking if a LTI dynamic system is passive or not is a simple matter. However, for uncertain systems, it becomes much more involved. In the present paper, we use the so-called integral quadratic constraints (IQC's) introduced in [20] and [21] to describe uncertain components. The IQC's encompass all of the commonly encountered types of uncertainty mentioned earlier. More will be said in Section III. Our first main result (in Section III) is a sufficient condition for guaranteeing the uncertain system to be strictly passive for all admissible uncertainty. This sufficient condition is expressed in terms of a linear matrix inequality (LMI) that can be solved efficiently. For details on LMI's, refer to [2]. The result above has two versions: one for continuous-time systems and one for discrete time systems.

Thus far, we have only addressed the passivity analysis problem. A companion problem is passivity synthesis, or passification, where we are required to design a passive system using a feedback/feedforward compensator subject to constraints. In signal processing systems, compensation is usually required to reconfigure a given system so that the resulting system, although equivalent to the original system as

TABLE I
NOTATIONS

Notation	Continuous	Discrete
ϱ	s	z
$\sigma x(t)$	$\dot{x}(t)$	$x(t+1)$
$S_0^T y(t)$	$\int_0^T y(t)dt$	$\sum_{t=0}^T y(t)$
\mathcal{L}_2^e	L_2^e	ℓ_2^e
$\langle x, y \rangle$	$\int_0^\infty x'(t)y(t)dt$	$\sum_{t=0}^\infty x'(t)y(t)$
$\langle x, y \rangle_T$	$\int_0^T x'(t)y(t)dt$	$\sum_{t=0}^T x'(t)y(t)$

far as stability is concerned, is more suitable for passivity and stability analysis. This approach is commonly used in stability analysis of nonlinear control systems; see [3], [10], and [15], for example. It is also used in [6] for analyzing the finite error recovery problem in the DFE.

The second main result of this paper, which is given in Section IV, deals with the passification problem for uncertain systems. Quite often in a signal processing system (see Fig. 1), one part of the system is “over passive,” whereas the other part is not passive. This makes the stability analysis difficult. Our interest then is to find an appropriate loop transformation, which is a kind of compensation that preserves the passivity of the former while passifying the latter. Passification of uncertain signal systems using four commonly used transformations will be studied in detail. It is noted that stability analysis for systems using multipliers and passivity has been studied in numerous papers; see, for example, [2] and [3]. The multipliers are simply “scalings.” Our results incorporate the commonly used loop transformations and provide a systematic search using an LMI approach to design the required loop transformations.

We also present illustrative examples in Section V to demonstrate our results. Some conclusions are drawn in Section VI.

II. PRELIMINARIES ON PASSIVITY

Table I is the table of notation that will be used throughout the paper.

In Table I, we denote by L_2^e (resp. ℓ_2^e) the extended real L_2 (resp. ℓ_2) space, i.e., $u \in L_2^e$ (resp. $u \in \ell_2^e$) if every truncated u belongs to L_2 (resp. ℓ_2). Without complicating the notation, we will use L_2 to denote $L_2 \times L_2 \times \dots \times L_2$, etc.

Definition 1—Passivity: An operator $\mathcal{H} : \mathcal{L}_2^e \rightarrow \mathcal{L}_2^e$ is called *passive* if there exists β (not necessarily positive) such that

$$\langle \mathcal{H}u, u \rangle_T \geq \beta, \quad \forall u \in \mathcal{L}_2^e, \quad T > 0. \quad (1)$$

Similarly, \mathcal{H} is called *strictly passive* if there exist β and $\alpha > 0$ such that

$$\langle \mathcal{H}u, u \rangle_T \geq \beta + \alpha \langle u, u \rangle_T, \quad \forall u \in \mathcal{L}_2^e, \quad T > 0. \quad (2)$$

When \mathcal{H} is a LTI real operator and it is passive (resp. strictly passive), its transfer function is called *positive real* (PR) [resp. *strictly positive real* (SPR)].

Remark 1: Although β is allowed to be nonzero in the definition above, it is known that β can be set to zero without loss of generality for linear operators.

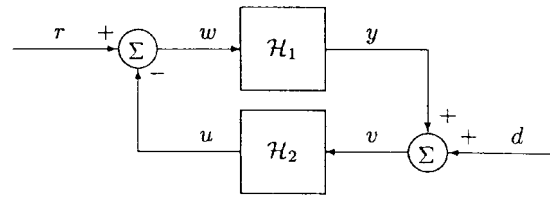

Fig. 1. Interconnected feedback system.

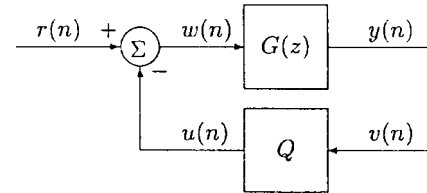

Fig. 2. Digital quantizer.

Definition 2—Bounded Realness: An operator $\mathcal{H} : \mathcal{L}_2^e \rightarrow \mathcal{L}_2^e$ is called *bounded real* if

$$\langle \mathcal{H}u, \mathcal{H}u \rangle_T \leq \langle u, u \rangle_T, \quad \forall u \in \mathcal{L}_2^e, \quad T > 0. \quad (3)$$

Similarly, \mathcal{H} is called *strictly bounded real* if there exists $0 < \alpha < 1$ such that

$$\langle \mathcal{H}u, \mathcal{H}u \rangle_T \leq \alpha \langle u, u \rangle_T, \quad \forall u \in \mathcal{L}_2^e, \quad T > 0. \quad (4)$$

Definition 3—Stability: An operator $\mathcal{H} : \mathcal{L}_2^e \rightarrow \mathcal{L}_2^e$ is called *stable* if $\mathcal{H}u \in \mathcal{L}_2$ for any $u \in \mathcal{L}_2$.

Consider the feedback system depicted in Fig. 1, where \mathcal{H}_1 is a linear operator, and \mathcal{H}_2 is a (possibly) nonlinear operator. The following key lemma reveals a sufficient condition for the stability of the interconnected system.

Lemma 1: Suppose \mathcal{H}_1 is linear and strictly passive, and \mathcal{H}_2 is passive. Then, the mapping from (r, d) to (w, v) is stable.

Proof: See [3, p. 182] and [6]. □

The passivity conditions given in the lemma above are usually quite conservative when used directly. Consider the digital quantizer depicted in Fig. 2. The LTI filter in the upper block is typically not passive even when it is FIR, whereas the lower block is usually not constrained by a passivity condition (often stronger than passivity). For example, a typical constraint for the quantizer when studying the limit cycles due to overflow (i.e., saturation) is given by $u(n) = \text{sat}(v(n))$, where $\text{sat}(\cdot)$ is a saturation function. Fortunately, there are several standard transformations we can apply on a given feedback system so that the resulting system will be more suitable for Lemma 1. These transformations are depicted in Fig. 3(a)–(d). The results are summarized below; see [3], [10], and [15] for details.

Lemma 2: Given the feedback system in Fig. 1, consider the transformed versions in Fig. 3. Suppose the operators \mathcal{C} and \mathcal{D} are linear and stable, and \mathcal{D} has stable inverse. Then, the stability of all these systems are equivalent.

For example, consider the overflow limit cycles problem for the quantization system in Fig. 2 [7]. To capture the overflow

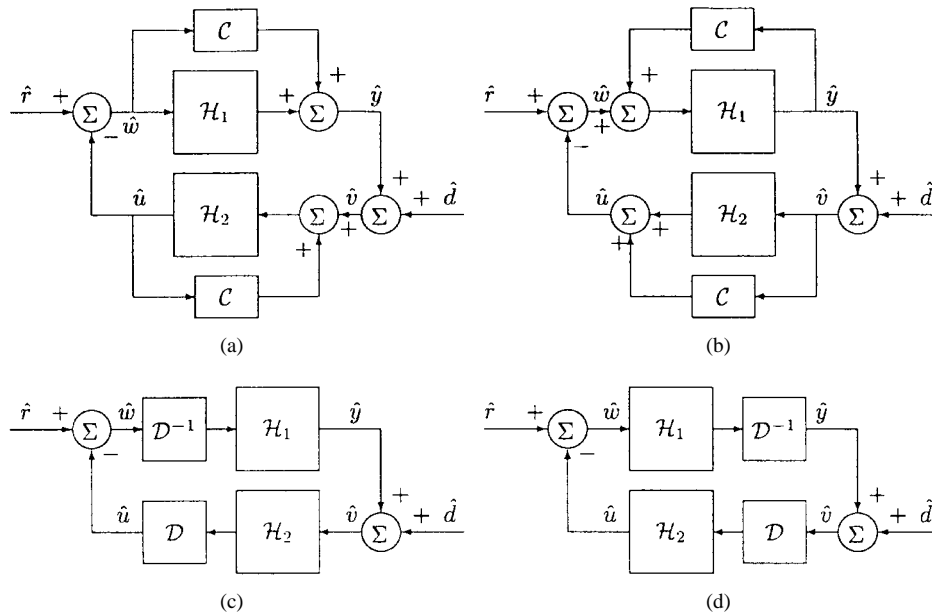

Fig. 3. Transformed feedback systems.

limit cycles, the quantizer is simplified and normalized to be

$$u(n) = \text{sat}(v(n)) = \begin{cases} -1, & v(n) < -1 \\ v(n), & |v(n)| \leq 1 \\ 1, & v(n) > 1. \end{cases} \quad (5)$$

Obviously, the quantizer is passive because $u(n)v(n) \geq 0$. Therefore, a direct application of Lemma 1 implies that no limit cycles exist when $G(z)$ is SPR. This is a well-known result; see [7]. However, this condition is too conservative in general. To reduce the conservatism, we consider the transformed system in Fig. 4, where $0 < \alpha < 1$ is a tuning parameter, and $H(z)$ is any stable function with L_1 norm less than or equal to 1, i.e.,

$$\mathcal{S}_0^\infty |h(t)| \leq 1 \quad (6)$$

where $h(t)$ is the impulse response corresponding to $H(z)$. In addition, it is required that $1 + H(z)$ is invertible.

It is known that the lower block of Fig. 4 is passive, whereas the upper block approaches $(1 + H(z))^{-1}(1 + G(z))$ when $\alpha \rightarrow 1$. Therefore, the system in Fig. 4 (hence, the one in Fig. 2) does not observe limit cycles if $(1 + H(z))^{-1}(1 + G(z))$ is SPR. Clearly, this is weaker than requiring $G(z)$ to be SPR because if $G(z)$ is indeed SPR, we can simply choose $H(z)$ to be zero. We also note that the condition above is a special case of a more general result studied by Zames and Falb [22], where the feedback block is allowed to be a general monotone and odd function (see [12]).

Another example where the transformation in Fig. 3(a) is used is the DFE problem studied in [6].

We note from the above discussions that two problems arise: 1) How do we test whether a given operator is passive or strictly passive, and 2) how do we find a suitable transformation using the combinations in Figs. 3(a)–(d) so that the stability problem of a given feedback system reduces to a passivity test.

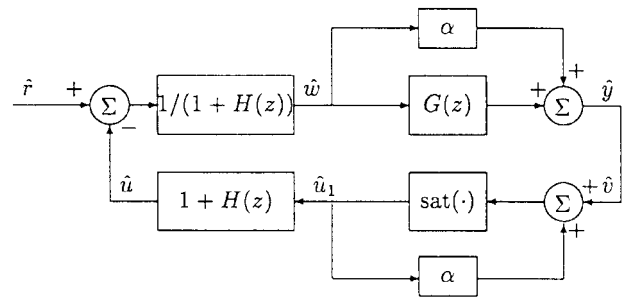

Fig. 4. Transformed quantizer system.

When the signal model under consideration contains no uncertainty, the well-known Kalman–Yakubovich–Popov (KYP) lemma (see [1] for an equivalent frequency domain condition) is a useful tool for addressing the above two problems. We shall recall this lemma below. To this end, we introduce the linear time-invariant system

$$(\Sigma_0): \sigma x(t) = Ax(t) + Bw(t) \quad (7)$$

$$y(t) = Cx(t) + Dw(t) \quad (8)$$

where $w(t) \in \mathbf{R}^q$ is the input, and $y(t) \in \mathbf{R}^q$ is the output.

The transfer function of (Σ_0) is given by

$$G(\rho) = C(\rho I - A)^{-1}B + D.$$

Note that as the number of inputs is equal to that of outputs, the above transfer function matrix is square.

Lemma 3: [1], [13] The system (Σ_0) is strictly positive real (see Definition 1) if and only if there exists a symmetric positive definite matrix P satisfying

$$\text{Continuous-time: } \begin{bmatrix} A'P + PA & PB - C' \\ B'P - C & -(D + D') \end{bmatrix} < 0 \quad (9)$$

and

$$\text{Discrete-time: } \begin{bmatrix} A'PA - P & (B'PA - C)' \\ B'PA - C & -(D + D' - B'PB) \end{bmatrix} < 0. \quad (10)$$

To conclude this section, we introduce the well-known \mathcal{S} procedure [20], [21], which will be used to handle passivity analysis and passification for uncertain signal models in the following sections.

Lemma 4: Let $\mathcal{F}(\cdot), \mathcal{Y}_1(\cdot), \dots, \mathcal{Y}_k(\cdot), \mathcal{Y}_{k+1}(\cdot), \dots, \mathcal{Y}_{k+l}(\cdot)$ be real-valued functionals defined on a set $\mathbf{\Lambda}$. Define the domain of constraints \mathbf{D} as

$$\mathbf{D} = \{\lambda \in \mathbf{\Lambda}: \mathcal{Y}_1(\lambda) \geq 0, \dots, \mathcal{Y}_k(\lambda) \geq 0, \mathcal{Y}_{k+1}(\lambda) = 0, \dots, \mathcal{Y}_{k+l}(\lambda) = 0\}$$

and two conditions

- a) $\mathcal{F}(\lambda) \geq 0, \forall \lambda \in \mathbf{D}$;
- b) $\exists \tau_1 > 0, \dots, \tau_k > 0, \tau_{k+1} \geq 0, \dots, \tau_{k+l} \geq 0$ such that

$$\mathcal{S}(\tau, \lambda) = \mathcal{F}(\lambda) - \sum_{j=1}^{k+l} \tau_j \mathcal{Y}_j(\lambda) \geq 0, \quad \forall \lambda \in \mathbf{\Lambda}$$

Then, b) implies a).

Remark 2: The procedure of replacing a) by b) is called the \mathcal{S} procedure. This procedure provides a very convenient way of handling inequality and equality constraints and is known to be conservative in general. Despite of its conservatism, the simplicity of this procedure has attracted a lot of applications in stability analysis problems and optimization problems; see [2], [12], [20], and [21]. In particular, searching for optimal scaling parameters τ_i is often a convex optimization problem, as we will see in the following sections.

III. PASSIVITY ANALYSIS

Consider the uncertain system

$$(\Sigma): \sigma x(t) = Ax(t) + Bw(t) + \sum_{i=1}^p F_{1i} \xi_i(t) \quad (11)$$

$$y(t) = Cx(t) + Dw(t) + \sum_{i=1}^p F_{2i} \xi_i(t) \quad (12)$$

$$z_i(t) = E_{1i}x(t) + E_{2i}w(t) + E_{3i}\xi(t) \quad i = 1, 2, \dots, p \quad (13)$$

where $x(t) \in \mathbf{R}^n$ is the state, $w(t) \in \mathbf{R}^q$ is the exogenous input, $y(t) \in \mathbf{R}^q$ is the output, $z_i(t) \in \mathbf{R}^{k_i}$, $i = 1, 2, \dots, p$, are fictitious outputs, and $\xi_i(t) \in \mathbf{R}^{k_i}$, $i = 1, 2, \dots, p$ denote uncertain variables. The system (Σ) is depicted in Fig. 5, where $z = [z_1' \ z_2' \ \dots \ z_p']'$, $\xi = [\xi_1' \ \xi_2' \ \dots \ \xi_p']'$, and Ψ represents the uncertain mapping. The uncertainty Ψ is called admissible if the uncertain variables satisfy the integral quadratic constraints (IQC's)

$$\lim_{T \rightarrow \infty} \mathbf{S}_0^T (\|\xi_i(t)\|^2 - \|z_i(t)\|^2) \leq 0, \quad i = 1, 2, \dots, p. \quad (14)$$

In the above, $A, B, C, D, F_{1i}, F_{2i}, E_{1i}, E_{2i}$, and E_{3i} are constant matrices of appropriate dimensions. In addition, note that the number of inputs is assumed to be equal to that of the outputs.

Remark 3: The uncertainty represented by the IQC's (14) is very general. It includes time delays, quantization errors, uncertain parameters, unmodeled dynamics, and many non-linear and/or time-varying components. A comprehensive list of uncertain components that can be described by IQC's can

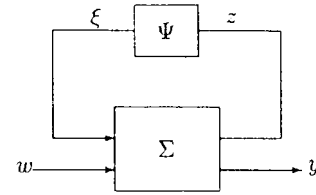

Fig. 5. Uncertain system Σ .

be found in a survey paper [12]. For example, the time-delay uncertainty $\xi_i(t) = z_i(t - \tau_i)$, $i = 1, 2, \dots, p$, where τ_i are the unknown delays and $\xi_i(t) = 0$ when $t \leq 0$, is a particular case of (14). An example of characterizing quantization errors by (14) can be found in Section V. In addition, the commonly used norm-bounded uncertainty [8], [18], [19], is a special case of the IQC's (14). In fact, the norm-bounded uncertainties can be described by the quadratic constraints

$$\|\xi_i(t)\|^2 \leq \|z_i(t)\|^2, \quad i = 1, 2, \dots, p. \quad (15)$$

Note that both (14) and (15) can effectively represent dynamic uncertain structure. However, the significant difference between (14) and (15) is that (15) are “instantaneous” constraints, whereas (14) are weaker “averaged” constraints. We also note that (14) can often be directly obtained from identification procedures.

Definition 4: The uncertain system (11)–(14) is called robustly passive (resp. robustly strictly passive) if it is passive (resp. strictly passive) for all admissible uncertainty.

Our objective is to analyze the robust strict passivity of the uncertain system (11)–(14).

Before proceeding further, we introduce the short-hand notation

$$F_1 = [F_{11} \ F_{12} \ \dots \ F_{1p}] \quad (16)$$

$$F_2 = [F_{21} \ F_{22} \ \dots \ F_{2p}] \quad (17)$$

$$E_3 = [E'_{31} \ E'_{32} \ \dots \ E'_{3p}]' \quad (18)$$

$$E = [E_1 \ E_2 \ E_3] \quad (19)$$

where τ_1, \dots, τ_p are scalars. The vector $\tau > 0$ if every component of τ is positive.

By applying the \mathcal{S} procedure stated in the previous section, we have the following result.

Lemma 5: The uncertain system of (11)–(14) is robustly strictly passive if there exist a symmetric positive definite matrix $P \in \mathbf{R}^{n \times n}$ and scaling parameters $\tau_1, \dots, \tau_p > 0$ such that

1) Continuous time:

$$2x'P \left(Ax + Bw + \sum_{i=1}^p F_{1i} \xi_i \right) - 2w'y + 2\alpha w'w + \sum_{i=1}^p \tau_i (\|z_i\|^2 - \|\xi_i\|^2) < 0 \quad (20)$$

2) Discrete-time:

$$\begin{aligned} & \left(Ax + Bw + \sum_{i=1}^p F_{1i}\xi_i \right)' P \left(Ax + Bw + \sum_{i=1}^p F_{1i}\xi_i \right) \\ & - x'Px - 2w'y + 2\alpha w'w + \sum_{i=1}^p \tau_i (\|z_i\|^2 - \|\xi_i\|^2) < 0 \end{aligned} \tag{21}$$

holds for some $\alpha > 0$, for all $x \in \mathbf{R}^n$, $w \in \mathbf{R}^q$ and $\xi_i \in \mathbf{R}^{k_i}$, $i = 1, 2, \dots, p$, such that $[x' \ w' \ \xi_1' \ \dots \ \xi_p'] \neq 0$.

Proof: Let $V(x) = x'Px$ and integrate the inequality of (20) from 0 to T along any trajectory of (11). Then, we have

$$\begin{aligned} & V[x(T)] - V[x(0)] - 2 \int_0^T w'(t)y(t) dt \\ & + 2\alpha \int_0^T w'(t)w(t) dt + \sum_{i=1}^p \tau_i \left\{ \int_0^T \|z_i\|^2 dt \right. \\ & \left. - \int_0^T \|\xi_i(t)\|^2 dt \right\} < 0. \end{aligned}$$

Now by taking $T \rightarrow \infty$ and considering (14) and the fact that $\tau_1, \tau_2, \dots, \tau_p > 0$, we have

$$\int_0^\infty w'(t)y(t) dt \geq -\frac{1}{2}V[x(0)] + \alpha \int_0^\infty w'(t)w(t) dt.$$

That is, the system (11)–(14) is robustly strictly passive.

The discrete-time case can be proven in a similar way. \square

With the above lemma, we present the first main result of this paper, i.e, we establish several equivalent conditions for the robust passivity of (11)–(14).

Theorem 1: Consider the uncertain system of (11)–(14). The following conditions, all guaranteeing the system to be robustly strictly passive, are equivalent.

- a) There exists $P = P' > 0$ such that (20) (continuous-time context) or (21) (discrete-time context) holds.
- b) For some $J > 0$ defined in (19), there exists $P = P' > 0$ such that

Continuous-time:

$$\mathcal{L}_{1c} = Q_c + E'JE < 0 \tag{22}$$

where

$$Q_c = \begin{bmatrix} A'P + PA & PB - C' & PF_1 \\ B'P - C & -(D + D') & -F_2 \\ F_1'P & -F_2' & -J \end{bmatrix}$$

Discrete-time:

$$\mathcal{L}_{1d} = Q_d + E'JE < 0 \tag{23}$$

where

$$Q_d = \begin{bmatrix} A'PA - P & A'PB - C' & A'PF_1 \\ B'PA - C & -(D + D' - B'PB) & B'PF_1 - F_2 \\ F_1'PA & F_1'PB - F_2' & F_1'PF_1 - J \end{bmatrix}.$$

- c) For some $J > 0$ of (19), there exists $P = P' > 0$ such that

Continuous-time:

$$\mathcal{L}_{2c} = \begin{bmatrix} Q_c & E'J \\ JE & -J \end{bmatrix} < 0 \tag{24}$$

Discrete-time:

$$\mathcal{L}_{2d} = \begin{bmatrix} Q_d & E'J \\ JE & -J \end{bmatrix} < 0. \tag{25}$$

- d) A is stable, and for some $J > 0$, either of the following auxiliary systems is strictly positive real:

$$\sigma x_a(t) = Ax_a(t) + [B \ F_1 \ 0]w_a(t) \tag{26}$$

$$y_a(t) = \begin{bmatrix} C \\ 0 \\ -JE_1 \end{bmatrix} x_a(t) + \begin{bmatrix} D & F_2 & 0 \\ 0 & \frac{1}{2}J & 0 \\ -JE_2 & -JE_3 & \frac{1}{2}J \end{bmatrix} w_a(t) \tag{27}$$

or

$$\sigma x_a(t) = Ax_a(t) + [B \ F_1J^{-1} \ 0]w_a(t) \tag{28}$$

$$y_a(t) = \begin{bmatrix} C \\ 0 \\ -E_1 \end{bmatrix} x_a(t) + \begin{bmatrix} D & F_2J^{-1} & 0 \\ 0 & \frac{1}{2}J^{-1} & 0 \\ -E_2 & -E_3 & \frac{1}{2}J^{-1} \end{bmatrix} w_a(t). \tag{29}$$

Moreover, the set of all J satisfying c) is convex, where J is given in (19).

Proof:

- a) \iff b): Using the short-hand notation of (16)–(19), (20) can be rewritten as

$$\begin{aligned} & 2x'P(Ax + Bw + F_1\xi) - 2w'(Cx + Dw + F_2\xi) \\ & + 2\alpha w'w + (x'E_1' + w'E_2' + \xi'E_3')J(E_1x \\ & + E_2w + E_3\xi) - \xi'J\xi < 0 \end{aligned}$$

which implies

$$[x' \ w' \ \xi'] \mathcal{L}_{1c} [x' \ w' \ \xi']' < 0$$

for all $x \in \mathbf{R}^n$, $w \in \mathbf{R}^q$, $\xi_i \in \mathbf{R}^{k_i}$, $i = 1, 2, \dots, p$ such that $[x' \ w' \ \xi_1' \ \dots \ \xi_p'] \neq 0$.

Conversely, if (22) holds, there exist some $\alpha > 0$ such that

$$\mathcal{L}_{1c} + \text{diag}\{0, 2\alpha I, 0\} < 0$$

which in turn guarantees the satisfaction of (20).

- b) \iff c): It follows the Schur complements, i.e.,

$$\begin{bmatrix} X_1 & X_2' \\ X_2 & -R \end{bmatrix} < 0 \iff X_1 < 0, \quad X_1 + X_2'R^{-1}X_2 < 0.$$

c) \iff d): By considering that $\mathcal{L}_{2c} < 0$ and $\text{diag}\{I, I, J^{-1}, J^{-1}\} \mathcal{L}_{2c} \text{diag}\{I, I, J^{-1}, J^{-1}\} < 0$, the equivalence follows immediately from Lemma 3.

The discrete-time case can be shown in a similar way. \square

Remark 4: Theorem 1 shows that the robust strict passivity of system (11)–(14) is guaranteed if the auxiliary system (26)–(27) or (28)–(29) is strictly positive real for some $J > 0$. It can be observed that all the inequalities in b) and c) of Theorem 1 are jointly linear in P and J . Therefore, all the inequalities in (22)–(25) are the linear matrix inequalities. Note that very efficient numerical algorithms exist for solving LMI's, owing to the recent advancement in *interior point algorithms* for convex optimization. See [2] for a good tutorial on this subject and implementations of algorithms. Software packages for solving LMI's are also available; see, e.g., [5].

IV. PASSIFICATION FOR UNCERTAIN SIGNAL SYSTEMS

In the previous section, we discussed the robust strict passivity problem for uncertain signal systems. As seen from Section II, there are many signal systems where certain transformations are needed to obtain a passivity property for certain constructing blocks of the systems; see Figs. 1 and 3. It is typical in signal processing systems (see Fig. 1) that the lower block is “over” passive, whereas the upper block is not passive enough. An example of this has been discussed in Fig. 2. In addition, the upper block contains uncertainty. In this section, we deal with the following robust passification problem: *Find one of the transformations described in Fig. 3 such that the passivity property for the lower block is preserved while the upper block is rendered to be strictly passive for all admissible uncertainty.*

First, we assume that the upper block of Fig. 1 is modeled by the system (Σ) given in (11)–(14), i.e., $\mathcal{H}_1 = \Sigma$. Denote the transformations \mathcal{C} , \mathcal{D} , or \mathcal{D}^{-1} all by \mathcal{T} . We consider a set of stable transformations that preserve the passivity of the lower block and have the form

$$\mathbf{T} = \left\{ \mathcal{T} : T(\varrho) = \sum_{i=1}^{\nu} \kappa_i T_i(\varrho), \quad \{\kappa_1, \kappa_2, \dots, \kappa_{\nu}\} \in \Omega \right\} \quad (30)$$

where $T_i(\varrho)$, $i = 1, 2, \dots, \nu$ are known transfer functions that can be regarded as basis functions of \mathcal{T} , and κ_i , $i = 1, 2, \dots, \nu$ are parameters to be designed that are constrained in a convex set Ω , which is typically a hypercube. Note that the above assumption is reasonable for many applications; see the example in [6] and Example 2 in the next section. It can be easily obtained that one particular state space realization for $T(\varrho)$ is of the form

$$T(\varrho) = \{A_c, B_c, C_c(K), D_c(K)\} \\ K = \{\kappa_1, \kappa_2, \dots, \kappa_{\nu}\} \in \Omega \quad (31)$$

where A_c, B_c are known constant matrices, and $C_c(K)$ and $D_c(K)$ are affine in K . Given \mathbf{T} , our objective is to choose a feasible K such that the transformed upper block is robustly strictly passive.

Remark 5: An alternative design procedure is to find a set of transforms that render the upper block strictly passive first, then select one from the set, if it exists, such that it also preserves the passivity of the lower block. The difficulty with this approach is that for a different upper block, the whole design must be redone. Although finding all transformations that preserve the passivity of the lower block is, in general, also a hard job, there are fortunately many standard lower blocks used in the signal processing problems, such as quantizers, sector-bounded uncertainties, etc. For these uncertainties, various transformations are known; see [6] and [12]. Hence, the approach we present in the paper should normally work better.

We now discuss each transformation in Fig. 3, respectively. For notational convenience, we define $z_f(t) = [z'_1(t) \ \dots \ z'_p(t)]'$.

Case (a) of Fig. 3:

In this case, the upper block is the sum of (\mathcal{C}) and (Σ) , and $\mathcal{T} = \mathcal{C}$. It is easy to obtain a state space realization for

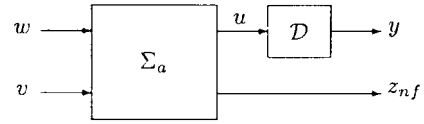

Fig. 6. Auxiliary system for $\mathcal{D}^{-1}\mathcal{H}_1$.

$(\mathcal{C}) + (\Sigma)$ as

$$(\Sigma_s): \sigma\eta(t) = \bar{A}\eta(t) + \bar{B}\hat{w}(t) + \bar{F}_1\xi(t) \quad (32)$$

$$\hat{y}(t) = \bar{C}\eta(t) + \bar{D}\hat{w}(t) + F_2\xi(t) \quad (33)$$

$$z_f(t) = \bar{E}_1\eta(t) + E_2\hat{w}(t) + E_3\xi(t) \quad (34)$$

where F_1, F_2, E_1, E_2, E_3 are defined in (18) and (19), and

$$\bar{A} = \begin{bmatrix} A & 0 \\ 0 & A_c \end{bmatrix}, \quad \bar{B} = \begin{bmatrix} B \\ B_c \end{bmatrix}, \quad \bar{F}_1 = \begin{bmatrix} F_1 \\ 0 \end{bmatrix} \quad (35)$$

$$\bar{C} = [C \quad C_c(K)], \quad \bar{D} = D + D_c(K), \quad \bar{E}_1 = [E_1 \quad 0]. \quad (36)$$

Apparently, the matrices \bar{C} and \bar{D} are affine in K ; all the other matrices are known.

By applying Theorem 1 to (Σ_s) , we have the following result.

Theorem 2: The system (Σ_s) is robustly strictly passive if there exists $J > 0$, $K \in \Omega$, and $P = P' > 0$ such that

Continuous-time:

$$\begin{bmatrix} \bar{A}'P + P\bar{A} & P\bar{B} - \bar{C}' & P\bar{F}_1 & \bar{E}_1'J \\ \bar{B}'P - \bar{C}' & -(\bar{D} + \bar{D}') & -F_2 & E_2'J \\ \bar{F}_1'P & -F_2' & -J & E_3'J \\ J\bar{E}_1 & JE_2 & JE_3 & -J \end{bmatrix} < 0 \quad (37)$$

Discrete-time:

$$\begin{bmatrix} \bar{A}'P\bar{A} - P & \bar{A}'P\bar{B} - \bar{C}' & \bar{A}'P\bar{F}_1 & \bar{E}_1'J \\ \bar{C}' - \bar{B}'P\bar{A} & -(\bar{D} + \bar{D}' - \bar{B}'P\bar{B}) & \bar{B}'P\bar{F}_1 - F_2 & E_2'J \\ \bar{F}_1'P\bar{A} & \bar{F}_1'P\bar{B} - F_2' & \bar{F}_1'P\bar{F}_1 - J & E_3'J \\ J\bar{E}_1 & JE_2 & JE_3 & -J \end{bmatrix} < 0. \quad (38)$$

Clearly, the LMI (37) or (38) is jointly linear in P, J , and K . Hence, they can be solved using convex optimization techniques; see [2] for details.

Case (c) of Fig. 3:

In this case, the upper block is a cascaded connection of \mathcal{D}^{-1} and \mathcal{H}_1 , and $\mathcal{T} = \mathcal{D}$. To overcome the difficulty of treating \mathcal{D}^{-1} , we will analyze its inverse instead. Our main idea can be observed from Figs. 6 and 7, where Σ_a is the auxiliary system to be defined in Theorem 3. First, it can be shown (see later) that the system in Fig. 7 is the inverse of that in Fig. 6. Hence, their strict passivity properties are equivalent. Next, it can be shown using Theorem 1 that the strict passivity of the system $\mathcal{H}_1\mathcal{D}^{-1}$ is guaranteed if \mathcal{D}^{-1} is such that the system in Fig. 7 is strictly passive or, equivalently, \mathcal{D} is such that the system in Fig. 6 is strictly passive.

We assume that the matrix D of (Σ) is invertible, which is in fact necessary for the strict passivity of the upper block of (a) and (d) (see later).

Then, our main result for Case (c) is stated in the following theorem.

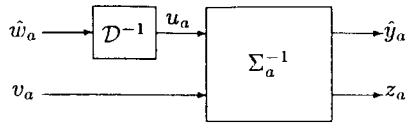

Fig. 7. Inverse system of the system in Fig. 6.

Theorem 3: Consider the system in Fig. 3(c) with $\mathcal{H}_1 = \Sigma$ defined in (11)–(14) and $\mathcal{D} = T(\rho)$ defined in (31). Then, \mathcal{D} renders the upper block of Fig. 3(c) robustly strictly passive if for some $J > 0$, \mathcal{D} is such that the system in Fig. 6 is strictly positive real, where the system (Σ_a) is given by

$$\Sigma_a = \{A_a, B_a, C_a, D_a\} \quad (39)$$

with

$$\begin{aligned} A_a &= A - BD^{-1}C \\ B_a &= [BD^{-1} \quad 2(F_1 - BD^{-1}F_2) \quad 0] \end{aligned} \quad (40)$$

$$C_a = \begin{bmatrix} -D^{-1}C \\ 0 \\ 2J(E_1 - E_2D^{-1}C) \end{bmatrix} \quad (41)$$

$$D_a = \begin{bmatrix} D^{-1} & -2D^{-1}F_2 & 0 \\ 0 & 2J & 0 \\ 2JE_2D^{-1} & 4J(E_3 - E_2D^{-1}F_2) & 2J \end{bmatrix} \quad (42)$$

and F_1, F_2, E_1, E_2 are the same as in (18) and (19).

Proof: First, note that the strict positive realness of the system in Fig. 6 implies that \mathcal{D} is invertible. This can be observed from \hat{D} in (55), which satisfies $\hat{D} + \hat{D}' > 0$. Next, denote $\mathcal{D}^{-1}(\rho) = (\hat{A}_c, \hat{B}_c, \hat{C}_c, \hat{D}_c)$. Then, a state space realization for the system $\mathcal{H}_1\mathcal{D}^{-1}$ is given by (Σ_s)

$$\sigma\eta(t) = \begin{bmatrix} A & B\hat{C}_c \\ 0 & \hat{A}_c \end{bmatrix} \eta(t) + \begin{bmatrix} B\hat{D}_c \\ \hat{B}_c \end{bmatrix} \hat{w}(t) + \begin{bmatrix} F_1 \\ 0 \end{bmatrix} \xi(t) \quad (43)$$

$$\hat{y}(t) = [C \quad D\hat{C}_c] \eta(t) + D\hat{D}_c \hat{w}(t) + F_2 \xi(t) \quad (44)$$

$$z_f(t) = [E_1 \quad E_2\hat{C}_c] \eta(t) + E_2\hat{D}_c \hat{w}(t) + E_3 \xi(t) \quad (45)$$

where z_f and ξ satisfy the IQC's (14). It follows from Theorem 1 that the system (Σ_s) is strictly passive for all admissible uncertainties if for some $J > 0$ the system

$$\begin{aligned} \sigma\eta(t) &= \begin{bmatrix} A & B\hat{C}_c \\ 0 & \hat{A}_c \end{bmatrix} \eta(t) + \begin{bmatrix} B\hat{D}_c & F_1J^{-1} & 0 \\ \hat{B}_c & 0 & 0 \end{bmatrix} \\ &\times \begin{bmatrix} \hat{w}_a(t) \\ v_a(t) \\ z_a \end{bmatrix} \\ &= \begin{bmatrix} C & D\hat{C}_c \\ 0 & 0 \\ -E_1 & -E_2\hat{D}_c \end{bmatrix} \eta(t) \\ &+ \begin{bmatrix} D\hat{D}_c & F_2J^{-1} & 0 \\ 0 & \frac{1}{2}J^{-1} & 0 \\ -E_2\hat{D}_c & -E_3J^{-1} & \frac{1}{2}J^{-1} \end{bmatrix} \begin{bmatrix} \hat{w}_a(t) \\ v_a(t) \end{bmatrix} \end{aligned} \quad (46)$$

is strictly passive. It is straightforward to show that the system (46)–(47) is in fact the system in Fig. 7, where (Σ_a^{-1})

$$\sigma x(t) = Ax(t) + [B \quad F_1J^{-1} \quad 0] \hat{u}_a(t) \quad (48)$$

$$\hat{y}_z(t) = \begin{bmatrix} C \\ 0 \\ -E_1 \end{bmatrix} x(t) + \bar{D}_a \hat{u}_a(t) \quad (49)$$

where $\hat{u}_a = [u_a' \ v_a']'$, $\hat{y}_z = [\hat{y}'_a \ z_a']'$, and

$$\bar{D}_a = \begin{bmatrix} D & F_2J^{-1} & 0 \\ 0 & \frac{1}{2}J^{-1} & 0 \\ -E_2 & -E_3J^{-1} & \frac{1}{2}J^{-1} \end{bmatrix}.$$

The strict positive realness of the system (46)–(47) ensures that the matrix \bar{D}_a is invertible. It can be shown that the system (Σ_a) is the inverse of (Σ_a^{-1}) . Thus, the system in Fig. 6 is the inverse of the system in Fig. 7. Therefore, the SPR of the system in Fig. 6 implies that of the system in Fig. 7, which in turn guarantees the robust strict passivity of $\Sigma_s = \mathcal{H}_1\mathcal{D}^{-1}$. \square

Given \mathcal{D} of the form (31), a state space realization for the system in Fig. 6 is of the form

$$\sigma\eta(t) = \hat{A}\eta(t) + \hat{B}w_v(t) \quad (50)$$

$$y_z(t) = \hat{C}\eta(t) + \hat{D}w_v(t) \quad (51)$$

where $y_z = [y' \ z_{nf}']'$, $w_v = [w' \ v']'$, and

$$\hat{A} = \begin{bmatrix} A_c & -B_cD^{-1}C \\ 0 & A - BD^{-1}C \end{bmatrix} \quad (52)$$

$$\hat{B} = \begin{bmatrix} B_cD^{-1} & -2B_cD^{-1}F_2 & 0 \\ BD^{-1} & 2(F_1 - BD^{-1}F_2) & 0 \end{bmatrix} \quad (53)$$

$$\hat{C} = \begin{bmatrix} C_c(K) & -2D_c(K)D^{-1}C \\ 0 & 0 \\ 0 & 2J(E_1 - E_2D^{-1}C) \end{bmatrix} \quad (54)$$

$$\hat{D} = \begin{bmatrix} D_c(K)D^{-1} & -D_c(K)D^{-1}F_2 & 0 \\ 0 & 2J & 0 \\ 2JE_2D^{-1} & 4J(E_3 - E_2D^{-1}F_2) & 2J \end{bmatrix}. \quad (55)$$

Obviously, the matrices \hat{A} and \hat{B} are known, whereas the matrices \hat{C} and \hat{D} are affine in unknown matrix K .

Now, an LMI for finding $\mathcal{D}(\rho)$ such that the upper block of Fig. 3(c) is robustly strictly passive is presented as follows.

Theorem 4: A given $\mathcal{D} \in \mathbf{T}$ defined in (30) and (31) renders the upper block of the system in Fig. 3(c) robustly strictly passive if there exist $J > 0$, $K \in \Omega$, and $P = P' > 0$ such that

$$\text{Continuous-time: } \begin{bmatrix} \hat{A}'P + P\hat{A} & P\hat{B} - \hat{C}' \\ \hat{B}'P - \hat{C} & -(\hat{D} + \hat{D}') \end{bmatrix} < 0 \quad (56)$$

$$\text{Discrete-time: } \begin{bmatrix} \hat{A}'P\hat{A} - P & (\hat{B}'P\hat{A} - \hat{C}') \\ \hat{B}'P\hat{A} - \hat{C} & -(\hat{D} + \hat{D}' - \hat{B}'P\hat{B}) \end{bmatrix} < 0 \quad (57)$$

holds, where $\hat{A}, \hat{B}, \hat{C}$, and \hat{D} are defined in (52)–(55).

Once again, the LMI's above are jointly linear in P, J , and K .

Case (d) of Fig. 3:

This case is similar to Case (c). The following result can be established by a similar way as in Case (c). The details of the proof are thus omitted.

Theorem 5: Consider the system in Fig. 3(d) with $\mathcal{H}_1 = \Sigma$ given in (11)–(14). A given $\mathcal{D} \in \mathbf{T}$ defined in (30)–(31) renders the upper block of the system robustly strictly passive if for some $J > 0$, \mathcal{D} is such that the system in Fig. 8 is strictly positive real, where the system (Σ_a) is given in (39).

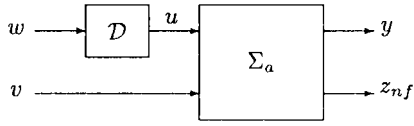
Fig. 8. Auxiliary system for $\mathcal{H}_1 D^{-1}$.

Remark 6: Note that for Case (d), we shall use the following different state space realization for $T(\varrho)$ in (30)

$$T(\varrho) = \{A_c, B_c(K), C_c, D_c(K)\}, \quad K \in \Omega \quad (58)$$

where A_c and C_c are constant matrices, and $B_c(K)$ and $D_c(K)$ are affine in K . Similar to Case (c), we can easily show that a state space realization for the system in Fig. 8 has constant \hat{A} and \hat{C} , but \hat{B} and \hat{D} are affine in K and J . Applying the KYP lemma on that state space representation, it can be verified that the resulting LMI's are jointly linear in P^{-1} , K , and J . In fact, by applying the Schur complements, it is easy to show that (56) and (57) are, respectively, equivalent to

$$\begin{aligned} \text{Continuous-time: } & \begin{bmatrix} P^{-1}\hat{A}' + \hat{A}P^{-1} & \hat{B} - P^{-1}\hat{C}' \\ \hat{B}' - \hat{C}P^{-1} & -(\hat{D} + \hat{D}') \end{bmatrix} < 0 \\ \text{Discrete-time: } & \begin{bmatrix} -P^{-1} & -P^{-1}\hat{C}' & P^{-1}\hat{A}' \\ -\hat{C}P^{-1} & -(\hat{D} + \hat{D}') & \hat{B}' \\ \hat{A}P^{-1} & \hat{B} & -P^{-1} \end{bmatrix} < 0. \end{aligned}$$

Case (b) of Fig. 3:

This case requires us to find K such that $\Sigma_s = (I - \mathcal{H}_1 C)^{-1} \mathcal{H}_1$ is strictly passive. If \mathcal{H}_1 is an invertible LTI system, the above is equivalent to the fact that the inverse system $\Sigma_s^{-1} = \mathcal{H}_1^{-1} - C$ is SPR. Note that Σ_s^{-1} is linear in K . When \mathcal{H}_1 involves uncertainty, we use a similar analysis as in Case (c), i.e., we can replace \mathcal{H}_1 by an auxiliary system that involves scaling parameters J but no uncertainty. Consequently, the robust passification problem becomes finding J and K such that the auxiliary inverse system $\Sigma_a^{-1} = \mathcal{H}_1^{-1} - C$ is SPR. As in Cases (c) and (d), it is assumed that D is invertible. The result is summarized below.

Theorem 6: Consider $C \in \mathbf{T}$ defined in (30) and (58). Then, C renders the robust strict passivity for the upper block if there exist $J > 0$, $K \in \Omega$, and $P = P' > 0$ such that the LMI (56) (continuous-time) or (57) (discrete-time) holds for

$$\hat{A} = \begin{bmatrix} A - BD^{-1}C & 0 \\ 0 & A_c \end{bmatrix} \quad (59)$$

$$\hat{B} = \begin{bmatrix} BD^{-1} & 2(F_1 - BD^{-1}F_2)J & 0 \\ B_c(K) & 0 & 0 \end{bmatrix} \quad (60)$$

$$\hat{C} = \begin{bmatrix} -D^{-1}C & -C_c \\ 0 & 0 \\ 2(E_1 - E_2D^{-1}C) & -2E_2C_c \end{bmatrix} \quad (61)$$

$$\hat{D} = \begin{bmatrix} D^{-1} - D_c(K) & -2D^{-1}F_2J & 0 \\ 0 & 2J & 0 \\ 2E_2(D^{-1} - D_c(K)) & 4(E_3 - E_2D^{-1}F_2)J & 2J \end{bmatrix}. \quad (62)$$

Proof: Note that the existence of a positive solution $P > 0$ to the LMI (56) or (57) implies that the system

$\Sigma_b = \{\hat{A}, \hat{B}, \hat{C}, \hat{D}\}$ is SPR. The SPR of (Σ_b) implies that $\hat{D} + \hat{D}' > 0$, which in turn ensures that $D^{-1} - D_c(K) + (D^{-1} - D_c(K))' > 0$. Hence, the matrix $D^{-1} - D_c(K)$ is invertible, i.e., the well posedness of C is guaranteed.

Now, the inverse system of (Σ_b) can be easily obtained as

$$\Sigma_b^{-1} = \{\hat{A}_{\text{inv}}, \hat{B}_{\text{inv}}, \hat{C}_{\text{inv}}, \hat{D}_{\text{inv}}\}$$

where

$$\hat{A}_{\text{inv}} = \begin{bmatrix} A & BC_c \\ 0 & A_c \end{bmatrix} + \begin{bmatrix} BD_c(K) \\ B_c(K) \end{bmatrix} M(K)^{-1} [C \quad DC_c]$$

$$\hat{B}_{\text{inv}} = [\hat{B}_1 \quad \hat{F}_1 \quad 0], \quad \hat{C}_{\text{inv}} = \begin{bmatrix} \hat{C}_1 \\ 0 \\ -J^{-1}\bar{E}_1 \end{bmatrix}$$

$$\hat{D}_{\text{inv}} = \begin{bmatrix} M^{-1}(K)D & M^{-1}(K)F_2 & 0 \\ 0 & \frac{1}{2}J^{-1} & 0 \\ -J^{-1}E_2 & -J^{-1}E_3 & \frac{1}{2}J^{-1} \end{bmatrix}$$

$$M(K) = I - DD_c(K),$$

$$\hat{B}_1 = \begin{bmatrix} B + BD_c(K)M^{-1}(K)D \\ B_c(K)M^{-1}(K)D \end{bmatrix}$$

$$\hat{F}_1 = \begin{bmatrix} F_1 + BD_c(K)M^{-1}(K)F_2 \\ B_c(K)M^{-1}(K)F_2 \end{bmatrix}$$

$$\hat{C}_1 = M^{-1}(K)[C \quad DC_c], \quad \bar{E}_1 = [E_1 \quad 0].$$

Apparently, the system (Σ_b^{-1}) is SPR, as is (Σ_b) .

Next, it can be worked out that the closed-loop system of the upper block of (b) in Fig. 3 is of the form

$$\sigma\eta(t) = \hat{A}_{\text{inv}}\eta(t) + \hat{B}_1\hat{w}(t) + \hat{F}_1\xi(t) \quad (63)$$

$$\hat{y}(t) = \hat{C}_1\eta(t) + M^{-1}(K)D\hat{w}(t) + M^{-1}(K)F_2\xi(t) \quad (64)$$

$$z_f(t) = \bar{E}_1\eta(t) + E_2\hat{w}(t) + E_3\xi(t) \quad (65)$$

where ξ and z_f satisfy the IQC's (14).

Finally, the robust strict passivity of the system (63)–(65) follows from the SPR of (Σ_b^{-1}) by employing Theorem 1. \square

It can be observed from (59)–(62) and Remark 6 that the LMI's in Theorem 6 are jointly linear in P^{-1} , J and K .

Remark 7: The results in Theorems 2–6 provide an LMI approach to the passification of uncertain signal processing systems. As powerful software packages are now available for solving LMI's [5], the proposed passification techniques should be useful in signal processing applications. See also the illustrative examples of the next section. It should be pointed out, however, that the results may be conservative due to 1) the use of the \mathcal{S} procedure, which provides, in general, a sufficient condition for passivity and passification, and 2) the use of a convex set of transformations \mathbf{T} . Nevertheless, we believe that our results provide a feasible way of handling uncertain signal processing systems.

V. ILLUSTRATIVE EXAMPLES

In this section, we will present two examples to demonstrate the applications of the results obtained in the previous sections. The first example examines the passivity analysis of a filter where quantization error exists. Our second example is concerned with the robust passification problem for a quantization system.

Example 1: Consider the overflow limit cycle problem associated with the digital quantizer in Fig. 2. Let $G(z)$ be of the form

$$G(z) = \frac{0.0375(z^2 + 0.6875z + 1)}{z^3 - 0.8750z^2 + (0.7500 + \delta a)z + (-0.625 + \delta b)} \quad (66)$$

where δa and δb represent the quantization errors after the corresponding coefficients are coded by 4 bits. It is known that $|\delta a| \leq 2^{-4}$ and that $|\delta b| \leq 2^{-4}$.

It can be easily checked that the nominal transfer function $G_0(z)$ of $G(z)$ (setting $\delta a \equiv 0$ and $\delta b \equiv 0$) is stable but not SPR. Next, let $H(z) = -G_0(z)$. It is verified that

$$C_0(z) = (1 + G_0(z))/(1 + H(z))$$

is SPR and that $\sum_{n=0}^{\infty} |h_n| < 1$, where $\{h_n\}$ is the impulse response of the system $H(z)$. Hence, from the discussions in Section II, we conclude that the system does not exhibit overflow limit cycles in the nominal case.

Next, we analyze the effect of the quantization errors. To this end, a state space realization for the transfer function

$$C(z) = (1 + G(z))/(1 + H(z))$$

is given by

$$x(k+1) = (A + \Delta A)x(k) + Bw(k) \quad (67)$$

$$y(k) = Cx(k) + Dw(k) \quad (68)$$

where

$$A + \Delta A = \begin{bmatrix} 0 & 1 & 0 \\ 0 & 0 & 1 \\ 0.6625 - \delta a & -0.7242 - \delta b & 0.9125 \end{bmatrix}$$

$$C = [0.075 \quad 0.0516 \quad 0.075], \quad D = 1.$$

Denote

$$F_{11} = F_{12} = \begin{bmatrix} 0 \\ 0 \\ -2^{-4} \end{bmatrix} \quad (69)$$

$$E_{11} = [1 \quad 0 \quad 0], \quad E_{12} = [0 \quad 1 \quad 0] \quad (70)$$

$$F_{2i} = 0, \quad E_{2i} = E_{3i} = 0, \quad i = 1, 2. \quad (71)$$

Then, the uncertainty $\Delta Ax(k)$ in (67) can be represented by $\Delta Ax(k) = F_{11}\xi_1 + F_{12}\xi_2$, where $\xi_i(k) = \delta_i z_i(k)$, $z_i(k) = E_{1i}x(k)$, and $|\delta_i| \leq 1$, $i = 1, 2$. Clearly, ξ_i and z_i satisfy the IQC's

$$S_0^T (\|\xi_i\|^2 - \|z_i\|^2) \leq 0, \quad i = 1, 2.$$

We now apply Theorem 1 to check whether $C(z)$ is SPR for any admissible quantization errors δa and δb . Efficient interior-point algorithms are available to solve (25) for some $P > 0$ and $J = \text{diag}\{\tau_1, \tau_2\} > 0$ [11]. These algorithms have been implemented in Matlab toolbox form [5]. Using the LMI toolbox on an HP workstation, a solution for (25) is obtained as $J = \text{diag}\{0.0422, 0.0413\}$, and

$$P = \begin{bmatrix} 0.7085 & -0.5375 & 0.2134 \\ -0.5375 & 1.1664 & -0.5843 \\ 0.2134 & -0.5843 & 0.8706 \end{bmatrix}.$$

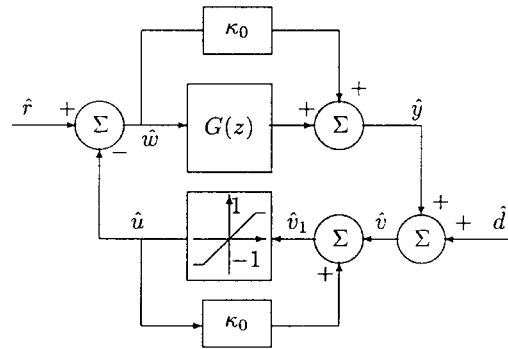

Fig. 9. Signal system of example 2.

Therefore, Theorem 1 and the results in Section II guarantee that the quantizer system will not have any overflow limit cycles, even when the quantization errors δa and δb are present.

Example 2: We consider a quantizer system in Fig. 9, where the IIR filter $G(z)$ is given in (66). As discussed earlier, without loop transformation (i.e., $\kappa_0 = 0$), the lower block of the system is passive. However, it can be checked that the upper block is not strictly passive. Our objective is to find a transformation in the form of Fig. 3(a), i.e., to find κ_0 , such that the lower block remains passive, whereas the upper block is rendered strictly passive for all admissible uncertainties (quantization errors).

Let κ_0 be a constant. The following lemma characterizes the set of κ_0 such that the lower block remains passive.

Lemma 6: Given the system in Fig. 9, the lower block of the system remains passive if $0 \leq \kappa_0 \leq 1$.

Proof: By direct calculation, for any $n \geq 0$

$$\hat{u}(n)\hat{v}(n) = \hat{u}(n)[\hat{v}_1(n) - \kappa_0\hat{u}(n)]$$

$$= \begin{cases} (1 - \kappa_0)\hat{v}_1^2(n), & |\hat{v}_1(n)| \leq 1 \\ \hat{v}_1(n) - \kappa_0, & \hat{v}_1(n) > 1 \\ -(\hat{v}_1(n) + \kappa_0), & \hat{v}_1(n) < -1. \end{cases}$$

It is obvious that $\hat{u}(n)\hat{v}(n) \geq 0$, $\forall n = 0, 1, 2, \dots$ if $0 \leq \kappa_0 \leq 1$. \square

Next since $C = \kappa_0$, the state space realization for C in (31) is

$$A_c = 0, \quad B_c = 0, \quad C_c(K) = 0, \quad D_c(K) = \kappa_0.$$

Similar to $C(z)$ in Example 1, a state-space realization for $G(z)$ is of the form (11)–(13) with the IQC's (14) and

$$A = \begin{bmatrix} 0 & 1 & 0 \\ 0 & 0 & 1 \\ 0.625 & -0.750 & 0.875 \end{bmatrix}, \quad B = \begin{bmatrix} 0 \\ 0 \\ 1 \end{bmatrix}$$

$$C = [0.0375 \quad 0.0258 \quad 0.0375], \quad D = 0$$

$F_{11}, F_{12}, E_{11}, E_{12}, F_{21}, F_{22}, E_{21}, E_{22}, E_{31}$, and E_{32} are as in (69)–(71).

Then, the augmented system (32)–(34) of C and G is readily obtained. Finally, by applying Theorem 2, five LMI's for solving the passification problem are given by (38) and

$$P > 0, \quad J > 0, \quad \kappa_0 > 0, \quad 1 - \kappa_0 > 0.$$

The following result is obtained from the Matlab toolbox [5]:

$\kappa_0 = 0.5, J = \text{diag}\{0.2746, 0.2690\}$, and

$$P = \begin{bmatrix} 3.7799 & -2.7652 & 1.2057 & 0 \\ -2.7652 & 6.0191 & -3.0012 & 0 \\ 1.2057 & -3.0012 & 4.5663 & 0 \\ 0 & 0 & 0 & 60.7533 \end{bmatrix}.$$

Hence, the required loop transformation is $\kappa_0 = 0.5$. The transfer function of the transformed upper block $\kappa_0 + G(z)$ is verified to be SPR for all admissible uncertainties.

VI. CONCLUSION

This paper has studied the problems of robust passivity analysis and passification for a large class of uncertain systems with the uncertainty described by integral quadratic constraints. LMI solutions have been presented. In view of recent development in convex optimization, especially in solving LMI's (see [2]), our results offer efficient solutions to these problems. Applications of these problems in signal processing systems have been studied. In particular, we note that passivity analysis is an important tool in studying robust stability of signal processing systems involving nonlinear elements. Examples of such systems (digital quantizers) have been presented.

REFERENCES

- [1] B. D. O. Anderson and S. Vongpanitlerd, *Network Analysis and Synthesis: A Modern Systems Theory Approach*. Englewood Cliffs, NJ: Prentice-Hall, 1973.
- [2] S. Boyd, L. El Ghaoui, E. Feron, and V. Balakrishnan, *Linear Matrix Inequalities in System and Control Theory*. Philadelphia, PA: SIAM, 1994.
- [3] C. A. Desoer and M. Vidyasagar, *Feedback Systems: Input-Output Properties*. New York: Academic, 1975.
- [4] M. Fu, N. E. Barabanov, and H. Li, "Robust H_∞ analysis and control of linear systems with integral quadratic constraints," Tech. Rep. EE9447, Dept. Elect. Comput. Eng., Univ. Newcastle, Callaghan, Australia, 1994.
- [5] P. Gahinet, A. Nemirovski, A. J. Laub, and M. Chilali, *LMI Control Toolbox—For Use with Matlab*. Natick, MA: The MATH Works, 1995.
- [6] R. A. Kennedy, B. D. O. Anderson, and R. R. Bitmead, "Channels leading to rapid error recovery for decision feedback equalizers: Passivity analysis," in *Proc. 27th IEEE Conf. Decision Contr.*, Austin, TX, 1988, pp. 2402–2407.
- [7] A. V. Oppenheim and R. W. Schaffer, *Discrete-Time Signal Processing*. Englewood Cliffs, NJ: Prentice-Hall, 1989.
- [8] P. P. Khargonekar, I. R. Petersen, and K. Zhou, "Robust stabilization of uncertain linear system: Quadratic stabilizability and H_∞ control theory," *IEEE Trans. Automat. Contr.*, vol. 35, pp. 356–361, 1990.
- [9] R. Lozano-Leal and S. M. Joshi, "Strictly positive real transfer function revisited," *IEEE Trans. Automat. Contr.*, vol. 35, pp. 1243–1245, 1990.
- [10] K. S. Narendra and J. H. Taylor, *Frequency Domain Criteria for Absolute Stability*. New York: Academic, 1973.
- [11] Y. Nesterov and A. Nemirovski, *Interior Point Polynomial Methods in Convex Programming: Theory and Applications*. Philadelphia, PA: SIAM, 1994.
- [12] A. Rantzer and A. Megretsky, "System analysis via integral quadratic constraints," in *Proc. IEEE Conf. Decision Contr.*, 1994, pp. 3062–3067.
- [13] W. Sun, P. P. Khargonekar, and D. Shim, "Solution to the positive real control problem for linear time-invariant systems," *IEEE Trans. Automat. Contr.*, vol. 39, pp. 2034–2046, 1994.
- [14] P. P. Vaidyanathan, *Multirate Systems and Filter Banks*. Englewood Cliffs, NJ: Prentice-Hall, 1993.
- [15] M. Vidyasagar, *Nonlinear Systems Analysis*. Englewood Cliffs, NJ: Prentice-Hall, 1993.
- [16] J. T. Wen, "Time domain and frequency domain conditions for positive realness," *IEEE Trans. Automat. Contr.*, vol. 33, pp. 988–992, 1988.
- [17] L. Xie and Y. C. Soh, "Positive real control of uncertain linear time-invariant systems," *Syst. Contr. Lett.*, vol. 24, pp. 265–271, 1995.
- [18] L. Xie, M. Fu, and C. E. de Souza, " H_∞ control and quadratic stabilization of systems with parameter uncertainty via output feedback," *IEEE Trans. Automat. Contr.*, vol. 37, pp. 1253–1256, 1992.
- [19] Y. Wang, L. Xie, and C. E. de Souza, "Robust control of a class of uncertain nonlinear systems," *Syst. Contr. Lett.*, vol. 19, pp. 139–149, 1992.
- [20] V. A. Yakubovich, "S-procedure in nonlinear control theory," *Vestnik Leningrad Universiteta, Ser. Matematika*, pp. 301–319, 1988.
- [21] ———, "Frequency conditions of absolute stability of control systems with many nonlinearities," *Automatica i Telemekhanika*, vol. 28, pp. 5–30, 1967.
- [22] G. Zames and P. L. Falb, "Stability conditions for systems with monotone and slope-restricted nonlinearities," *SIAM J. Contr.*, vol. 6, pp. 89–108, 1968.



Lihua Xie (SM'96) was born in Fujian, China, in 1964. He received the B.E. and M.E. degrees in control engineering from Nanjing University of Science and Technology, Nanjing, China, in 1983 and 1986, respectively, and the Ph.D. degree in electrical engineering from the University of Newcastle, Callaghan, Australia, in 1992.

From April 1986 to January 1989, he was a Teaching Assistant and then a Lecturer in the Department of Automatic Control, Nanjing University of Science and Technology. He joined the Nanyang Technological University, Singapore, in 1992, where he is currently a Senior Lecturer at the School of Electrical and Electronic Engineering. His current research interests include filtering and signal processing, robust control and estimation, model reduction, and nonlinear systems.



Minyue Fu received the Bachelors degree in electrical engineering from the China University of Science and Technology, Hefei, in 1982 and the M.S. and Ph.D. degrees in electrical engineering from the University of Wisconsin, Madison, in 1983 and 1987, respectively.

From 1983 to 1987, he held a Teaching Assistantship and a Research Assistantship at the University of Wisconsin, Madison. He worked as a Computer Engineering Consultant at Nicolet Instruments, Inc., Madison, WI, during 1987. From 1987 to 1989, he served as an Assistant Professor in the Department of Electrical and Computer Engineering, Wayne State University, Detroit, MI. During the summer of 1989, he was employed by the Université Catholique de Louvain, Louvain, Belgium, as a Maitre de Conférences Invited. He joined the Department of Electrical and Computer Engineering, the University of Newcastle, Callaghan, Australia, in 1989, where he now holds an Associate Professorship. His main research interests include robust control, dynamical systems, stability, and signal processing.

Dr. Fu has been an Associate Editor of the IEEE TRANSACTIONS ON AUTOMATIC CONTROL and an Associate Editor for the Conference Editorial Board of the IEEE Control Systems Society.



Huaizhong Li was born in Jiangsu, China, in 1964. He received the B.Sc. and M.Sc. degrees from East China Institute of Technology, Nanjing, in 1983 and 1986, and the Ph.D. degree in electrical engineering from University of Newcastle, Callaghan, Australia, in 1996.

He worked from April 1986 to July 1991 at East China Institute of Technology, Shanghai. From October 1995 to October 1997, he was awarded a "Sejour Scientifique de Longue Durée" fellowship by the French government and worked as a post-doctoral fellow at Laboratoire d'Automatique de Grenoble, Grenoble, France. He is currently with School of Engineering, Murdoch University, Perth, Australia. His research interests include signal processing, robust control theory, and applications to process control.